

ACCESSORIES

Z BRACKETS Z-380M



Z-380M

“TAROS” Mounting “Z” bracket

Material : Aluminum

Dimensions

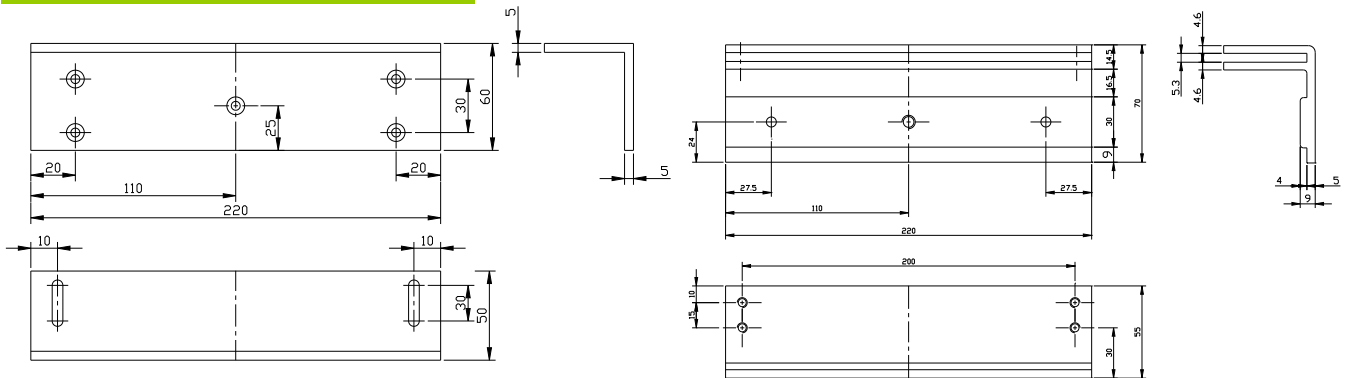

Installation

Face Mounting Electromagnetic Lock with “Z” Bracket for Inswing Door

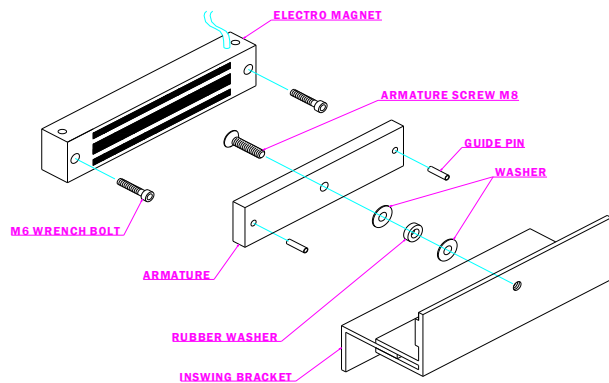
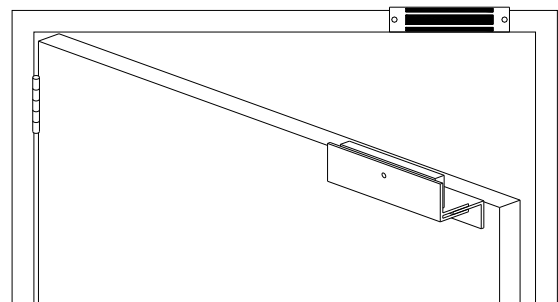
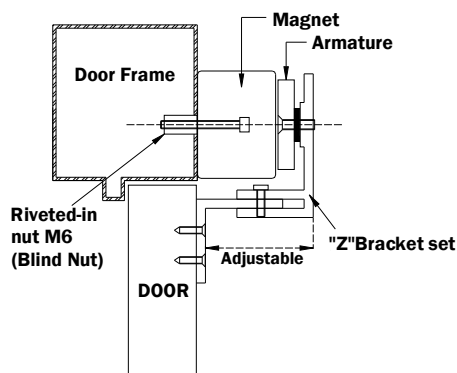

DOORNICS CO., LTD.

SK Techno B/D No. 903, 16-4, Seongsu-Dong 1-Ga, Seongdong-Gu,
 Seoul, 133-112, Korea
 Tel : +82-2-3409-2590~4 Fax : +82-2-3409-2100
 E-mail : doornics@chollian.net Website : www.doornics.co.kr



The products are manufactured under an ISO 9001 & 2000 and Certified CE.

Various Mounting methods

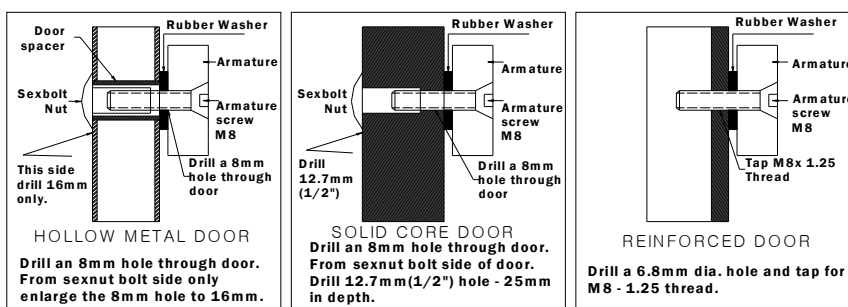
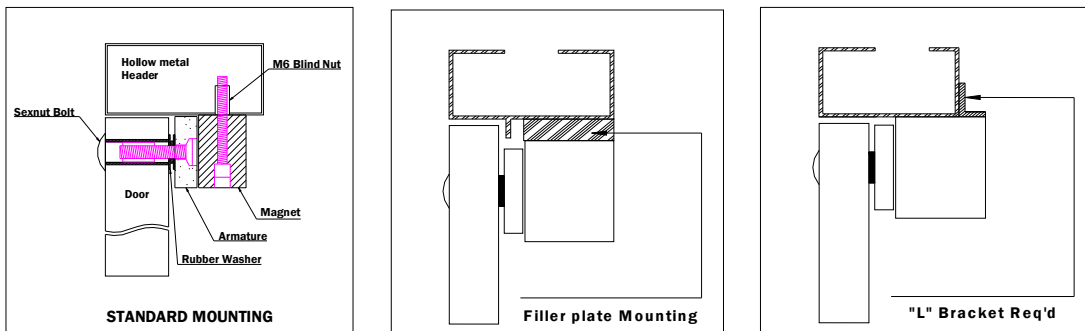

Fix the Armature plate not too tightly, to let the rubber washer move, in order to make the Armature plate automatically adjust to the proper position with the magnet.

Order Details

Model No. Description

EM-380M "TAROS" Electromagnetic Lock (850lbs / 380kg)



Z-380M "TAROS" Mounting "Z" bracket



DOORNICS CO., LTD.

SK Techno B/D No. 903, 16-4, Seongsu-Dong 1-Ga, Seongdong-Gu, Seoul, 133-112, Korea
 Tel : +82-2-3409-2590~4 Fax : +82-2-3409-2100
 E-mail : doornics@chollian.net Website : www.doornics.co.kr



The products are manufactured under an ISO 9001 & 2000 and Certified CE.